

Aufbereitete Rippe

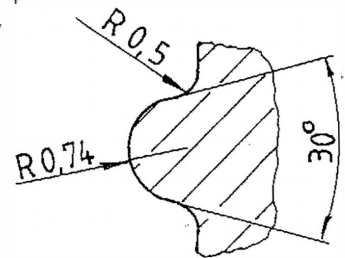

Gew.Stgg.: 3mm

36 Rippen

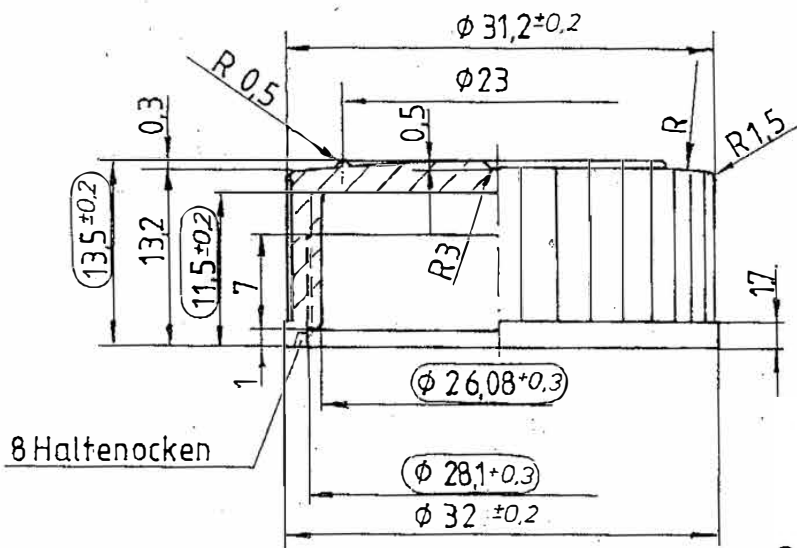
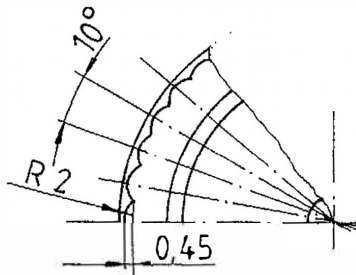

Artikelmaße!

 Funktionsmaße/Kontrollmaße

Zeichnungsnummer 24.224/23.302		Material: PP		Maßstab 2 : 1	
				Verschluß DIN 28 plan	
		92 Datum Name Bearb. 29.06. <i>Vde</i>		KI-SI-CO Kunststoffverarbeitung	
		Gepr.		6227 Oestrich-Winkel	
				Com.	
				Blatt	
				Bl.	
Zust.	Änderung	Datum	Name		