

COLOUR	SAP SPEAKING NO	SAP MATERIAL NO
Standard amber	20 - 12597 - 0	31002597

müller+krempel 

14.017.00

Bottom view

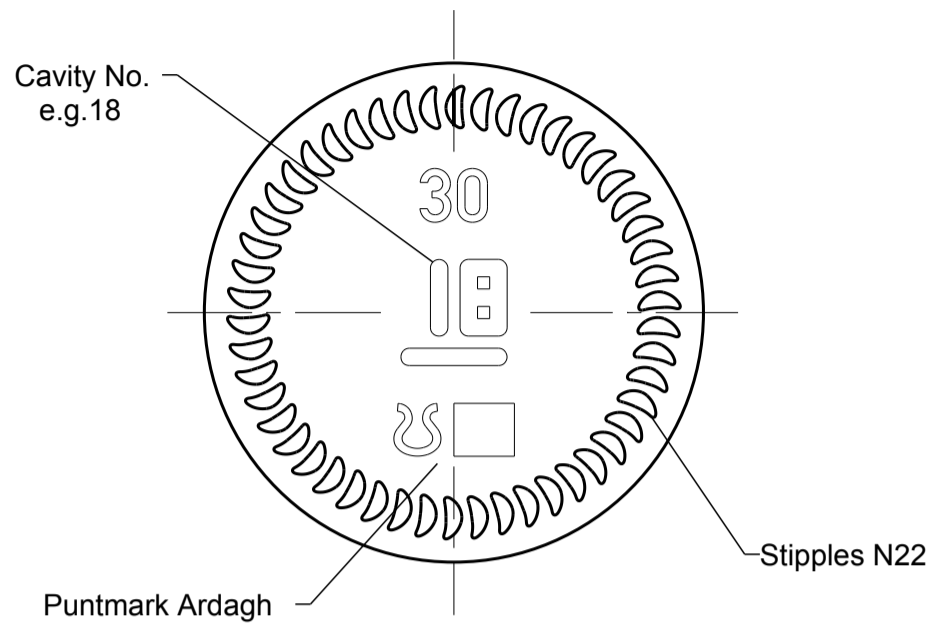

Front view

PP 28 S DIN6094-7:1995-02

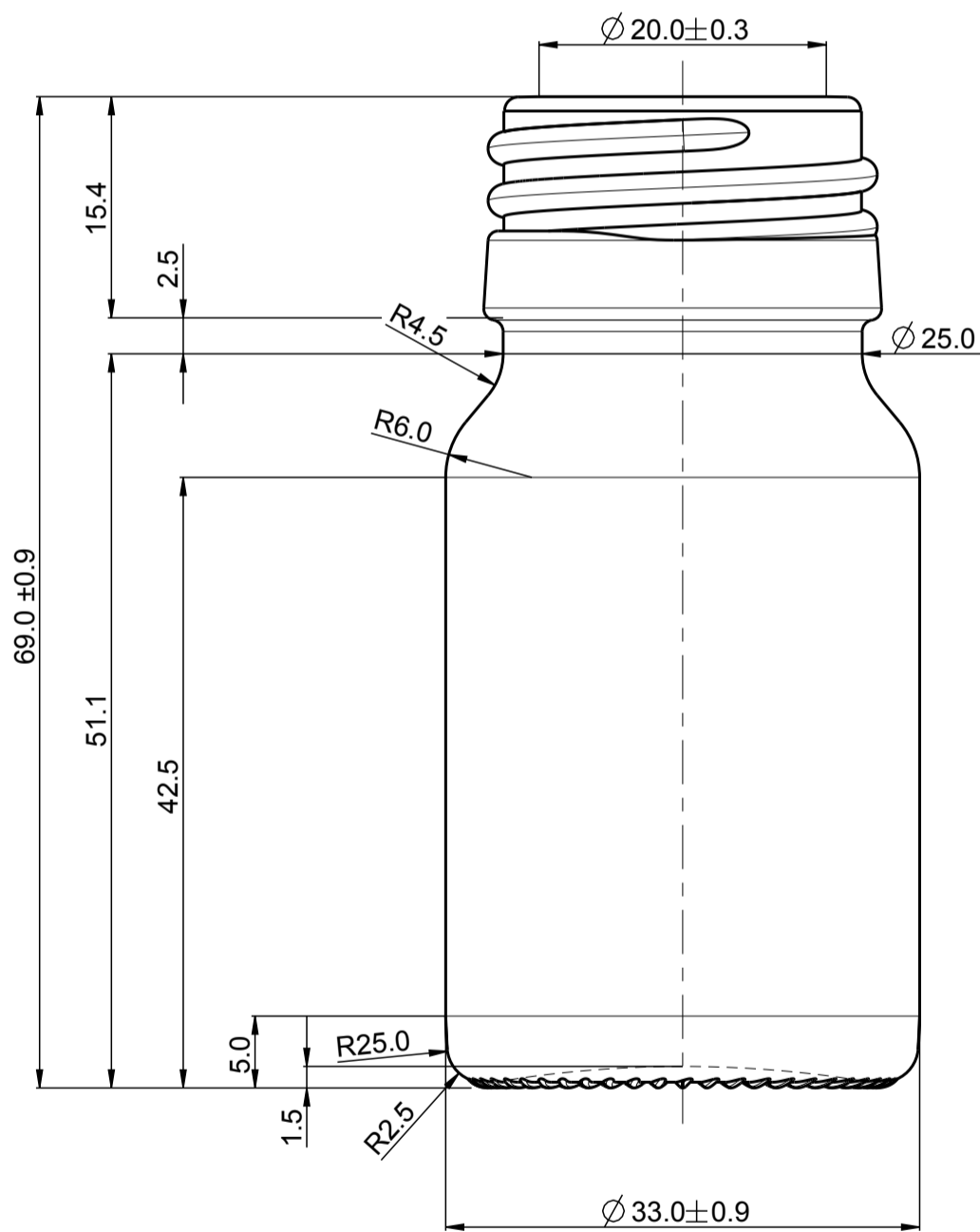

1:1

0.4 STIPPLE HEIGHT IS INCLUDED IN ALL DIMENSIONS FROM THE BASE

Nenninhalt NOMINAL CAPACITY	<b>30 ml</b>	SPECIFICATION AGREEMENTS ARE BASED ON TOLERANCED DIMENSIONS ONLY DO NOT SCALE DRAWING COPYRIGHT RESERVED, NOT TO BE COPIED IN WHOLE OR PART WITHOUT WRITTEN PERMISSION FROM ARDAGH GLASS LTD.  ALL DIMENSIONS ARE IN MILLIMETERS  Document supervised by SAP, cProject and Windchill PDMLink systems) Allgemeintoleranzen vollautomatisch gefertigter Flaschen gemäß DIN 6129	Product & Mould Design	ArdaghGroup 
Randvollinhalt BRIMFULL CAPACITY	<b>34 ml ± 1 ml</b>			
Kopfraum VACUITY	<b>4 ml (13.3 %)</b>		Glass - Europe	
Mündungsbezeichnung FINISH DESCRIPTION	<b>PP 28 S</b>		Gezeichnet DESIGNER	ukreft
Mündungs-Nummer FINISH NUMBER	<b>AF02010</b>		Datum DATE	27.12.2011
Bohrungsdurchmesser min MINIMUM THROUGH BORE	<b>18.0 mm</b>		Kunde CUSTOMER	Projekt PROJECT
Gewicht WEIGHT NOMINAL	<b>~43 g</b>		Produkt Name / PRODUCT NAME	
Verwendung USAGE	<b>NON RETURNABLE</b>		<b>SIRUPFLASCHE_30_C20_28PP</b>	
Druck CARBONATION	-	C Add brimful tolerance and minimum through bore	LingemannS	-
Kippwinkel TILT ANGLE	<b>~27°</b>	B Add SAP-Materialnumber	ukreft	-
		A First drawing	ukreft	-
		Änderung / REVISION	Erstellt/DSG	Sepru/CHW
			Datum / DATE	
			Alte Nummer OLD NUMBER	
			Zeichnungs Nr./DRAWING No.	Produkt Code / PRODUCT Code
			<b>D 11927 C</b>	<b>12597 - 0</b>