

Art. Nr.
W.Nr.
Freigabe
Datum:
Firma:

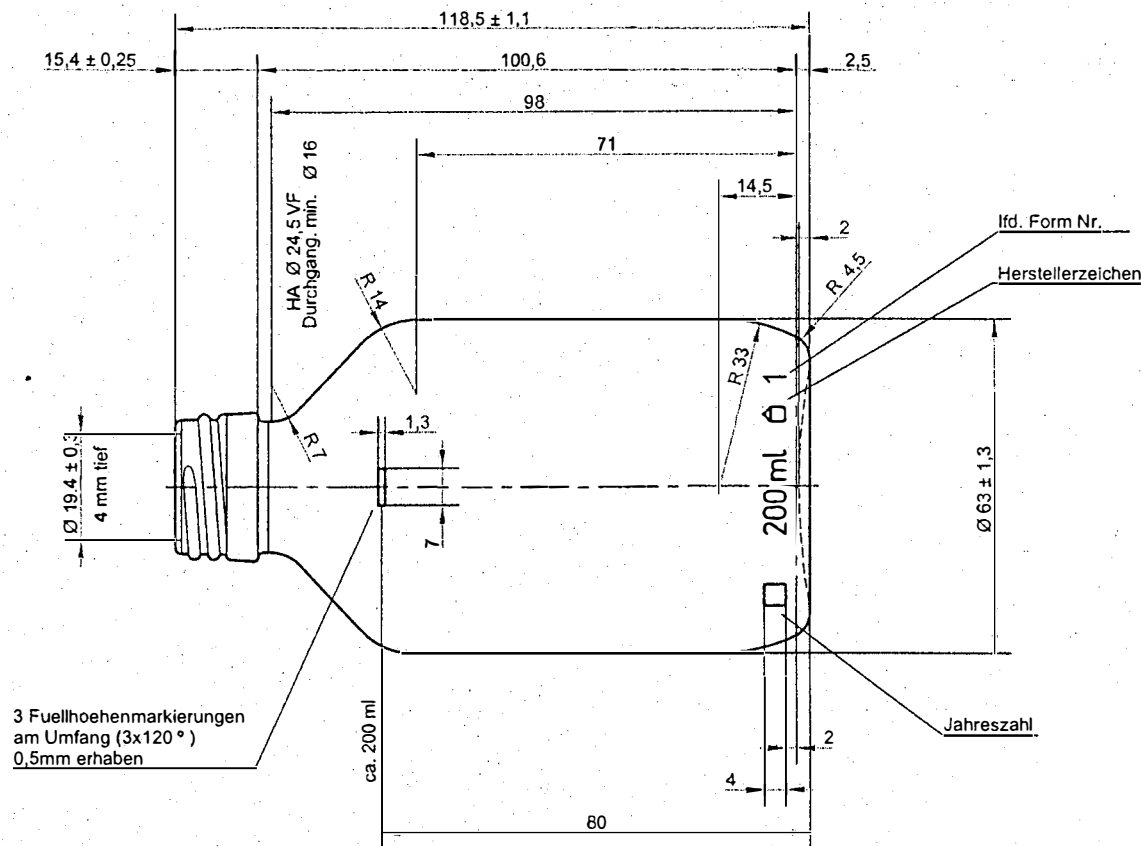

müller+krempel  
14.017.22

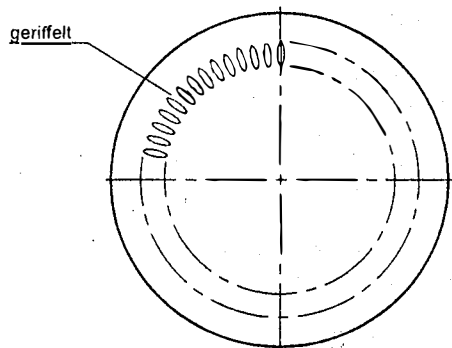

Rueckseite

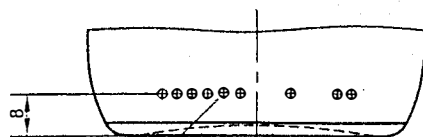

Kode

AQ305421

a	4 mm tief		27.04.05	Mi					
	Aenderung	It. Anw.	Datum	Name	Aenderung	It. Anw.	Datum	Name	
Bearb.	Just	17.01.03	PP28S DIN 6094-7	Glasgewicht	ca. 125 gr.	 <b>Spessart Glas</b> GmbH 97816 Lohr a. Main			
Gepr.				Inhalt rv.	226 ml ± 4,5				
Form Nr.	8430 -2	Maßstab	1:1	Benennung:	200 ml Verpackungsflasche				
						Zeichnungs Nr.	105693		